



DEW 50 Mobile Dehumidifier

- **Process Air:** Flow rates of 30-50 scfm. Nominal moisture removal: 24 lbs/24 hour at 83 °F
- **Utilities:** 115V/1 Phase 60Hz. Power required: 0.74kW; reactivation heater: 0.65kW
- **Electrical Controls:** Socket for humidistat plug-in provided
- **Drive System:** Desiccant rotor with belt drive
- **Reactivation Utility:** Energy modulation independently controls heater power to limit energy consumption.

Model DEW 50

Munters combines state-of-the-art desiccant technology with dependability and long operating life for humidity control at virtually any temperature. Dry air protection improves readiness, reduces maintenance costs, improves diagnostics, reduces HAZMAT and increases productivity.

With dehumidification, the following problems are eliminated in thousands of military applications:

Electronic Failures: Advanced electronics are extremely sensitive to moisture. Dehumidification eliminates moisture formation, precluding downtime and malfunction.

Corrosion: With dehumidification, moisture that causes rust and corrosion cannot condense on surfaces.

Diagnostic "Ghosts": Moisture is the leading cause of diagnostic "ghosts." Using dehumidification protection greatly reduces their occurrence.

Mold and Mildew: Dry air keeps surfaces moisture-free, therefore preventing the onset of mold and mildew.



DEW 50 with optional protective cage

Munters HoneyCombe® Rotor Technology

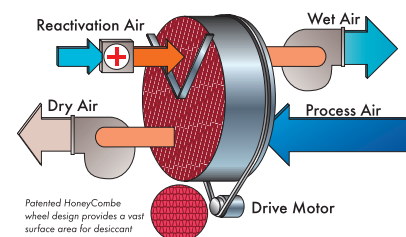

DEW 50 Dimensions Table

Model	Max Length (in.)	Max Width (in.)	Max Height (in.)	Max Weight (lb.)	Typical External Static Pressures (in. W.G.)	
					Process	React
DEW 50	10 3/4	10 3/4	15 1/4	22	0.44	0.40
DEW 50 Turnkey Configuration	15 3/4	13	20	35	0.44	0.40

Specifications

- Utilities:** DEW 50 = 115 V/1 Phase/60Hz
- Process Volume:** 50 scfm
- Max Reactivation Volume:** 10 scfm
- Max Reactivation Heater:** 0.65 kW
- Max dBA:** 70 or less (three feet from dehumidifier except in path of air flows)

DEW 50 Turnkey Configuration

The DEW 50 with turnkey configuration is a rugged (built of die-cast heavy aluminum casing), easy-to-install, dependable dehumidification solution for a wide range of applications such as combat vehicles, ISU and ISO containers, electronic shelters, ground-based radar systems, arms rooms and small supply spaces, or where electronics are housed or transported.

Advantages include:

Protective Cage: (Optional) Contained in a damage-resistant aluminum cage, the unit bolts directly to walls, ceilings or floors.

Automatic Function: Humidistat with on/off function, provides (auto) control of desired humidity levels and economical operation.

Duct Transitions: Standard ductwork easily connects to direct dry air to needed location.

Easy to Maintain: Filters are changed without tools and disconnections.

Suggested Specification Guide

Dehumidifier shall be of the Honeycombe® desiccant wheel type capable of continuous operation in ambient temperatures ranging from -40°F to 120°F. Desiccant wheel shall have a Honeycombe® structure with the desiccant impregnation of the wheel of such quality that the process and reactivation process can be efficiently performed while in continuous operation without replenishment or replacement of the desiccant required for 30,000 hours or more under normal operating conditions. The wheel shall be positioned within the dehumidifier casing so as to allow for the smallest and lightest weight equipment design per 30-50 scfm of delivered process air flow.

Fully assembled overall dimensions shall not exceed 10.75"(l) X 10.75"(w) X 15.25"(h) and 22 lb; or if turnkey configuration: 15.75"(l) X 13"(w) X 20"(h) and 35 lbs. Unit shall be energy efficient with total connected load not to exceed 0.74kW. Unit shall be shipped complete with reactivation heaters, filters, motors, fans, desiccant wheel drive unit and



electrical controls. The filters for process air and reactivation air shall be easily accessible and not require the use of tools.

Dehumidifier casing shall be constructed of aluminum for maximum strength, durability and corrosion resistance. Unit shall be painted with a polyurethane coating. Dehumidifier shall be capable of removing moisture from the air at various conditions. Equipment shall not employ chlorofluorocarbons which may pose an environmental threat to the ozone layer. Packaging and preservation is commercial. Equipment shall have a one year warranty.

Left View

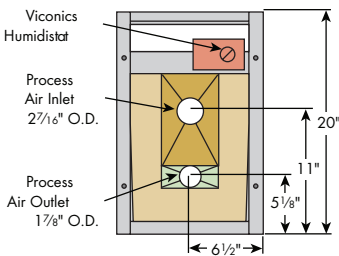

Front View

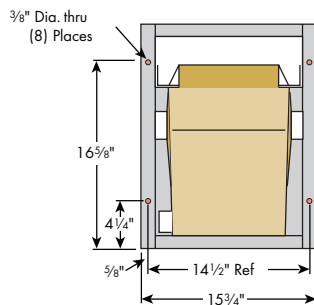

Right View

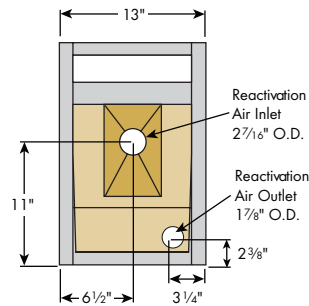

Top View

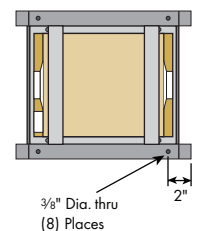

Australia Phone +61 2 8843 1580, serviceairt@munters.com.au Austria Phone +43 1 6164298-0, service.dh@munters.at Belgium & Luxembourg Phone +32 2 240 6868, service.dh@muntersnv.be Brazil Phone +55 41 3317 5050, munters@com.br Canada Phone +1 905 858 5894, dhinfo@munters.com China Phone +86 10 8041 8000, serviceairt@munters.cn Czech Republic Phone +420 544 211 434, servicecz@munters.de Denmark Phone +45 4495 3355, service.dh@munters.dk Finland Phone +358 40 186 3074, service.dh@munters.fi France Phone +33 1 3411 5757, service.dh@munters.fr Germany Phone +49 40 87 96 90-0, service.dh@munters.de India Phone +91 20 6681 8900, serviceairt@munters.in Italy Phone +39 0183 521 377, service.dh@munters.it Japan Phone +91 3 5970 0021, serviceairt@munters.jp Korea +82 2 761 8701, serviceairt@munters.co.kr Mexico Phone +52 722 270 4029, servicedhmx@munters.com Netherlands Phone +31 172 43 32 31, service@munters.nl Poland Phone +48 58 305 35 17, service.dh@munters.pl Singapore Phone +65 6744 6828, serviceairt@munters.com.sg South Africa Phone +27 11 971 9700, info@munters.co.za Spain & Portugal Phone +34 91 640 09 02, service.dh@munters.es Sweden & Norway Phone +46 8 626 6300, service.dh@munters.se Switzerland Phone +41 52 3438886, service.dh@munters.ch Thailand Phone +66 2 6422 6703, serviceairt@munters.com.sg Turkey Phone +90 216 548 1444, serviceairt@munters.com.tr UAE +971 4881 3026, middle.east@munters.com United Kingdom & Ireland Phone +44 1480 432243, service.dh@munters.co.uk USA Phone +1 800 843 5360, dhinfo@munters.com Vietnam Phone +84 8 3825 6838, vietnam@muntersasia.com



Munters Corporation
Tel: (800) 843-5360 E-mail: dhinfo@munters.com
www.munters.com